

MODEL NUMBER	IEEE1-12-145T		
HORSEPOWER	1		
RPM / POLES	1200 / 6		
VOLTAGE / PHASE	460 / 3		
FRAME	145T		
ENCLOSURE / DEGREE OF PROTECTION	TEFC / IP56		
FREQUENCY	60 HZ		
FULL LOAD SPEED	1140 RPM		
SERVICE FACTOR	1.15		
INSULATION CLASS	F Class N Varnish		
FULL LOAD AMPS; 460	1.8 A		
LOCKED ROTOR CURRENT (% Full Load)	800 %		
NEMA CODE LETTER	N		
EFFICIENCY / POWER FACTOR	<u>LOAD</u>	<u>EFF.</u>	<u>P.F.</u>
	100 %	82.5 %	65.0 %
	75 %	82.7 %	53.0 %
	50 %	79.0 %	39.0 %
DUTY CYCLE	S1 / Continuous		
TORQUE	<u>FULL LOAD</u>	<u>LRT</u>	<u>BDT</u>
	4.6 lb.ft	180 %	275 %
NEMA DESIGN	B		
MOMENT OF INERTIA	<u>LOAD (Max.)</u>	<u>MOTOR</u>	
	47.461 lb.ft <sup>2</sup>	0.083 lb.ft <sup>2</sup>	
SOUND PRESSURE LEVEL ( No Load 1 M From Motor)	55 dB(A)		
MAX. SHAFT VIBRATION	0.08 In/Sec – Peak Velocity		
NUMBER OF STARTS (Hot / Cold)	2 Hot / 3 Cold		
MAX. AMBIENT TEMPERATURE	40° C		
MAX. ELEVATION	3300 Ft. Above Sea Level		
TEMPERATURE RISE (At Full Load)	80° C		
DRIVE-END BEARING	6205ZC3		
OPPOSITE DRIVE-END BEARING	6204ZC3		
BEARING SEAL TYPE	ProTech™ IP66 Labyrinth On DE and ODE		
GREASE TYPE	Mobil Polyrex EM		
MOUNTING	F1 (F2 Suitable), W6, W8, B3, V5, V6		
ROTATION	Bi-Directional		
APPROXIMATE WEIGHT	55 lbs		
AREA CLASSIFICATION	Class I, Division 2, Groups A, B, C, D, T3A		
PAINT	Epoxy		
INVERTER RATING	10:1 CT / 1000:1 VT		
INSULATION TYPE	Hyundai Inverter Shield, Meets NEMA MG1 Part 31		
SPECIFICATION - In Accordance With	IEEE-841, Version 2009, NEMA, CSA		



CC 038A





**1 E E E 8 4 1 TEFC**

**THREE PHASE INDUCTION MOTOR**

**TYPE**

PLP

CAST IRON FRAME

FRAME SIZE

OUTPUT(HP)

POLES

Hz

TIME RATING

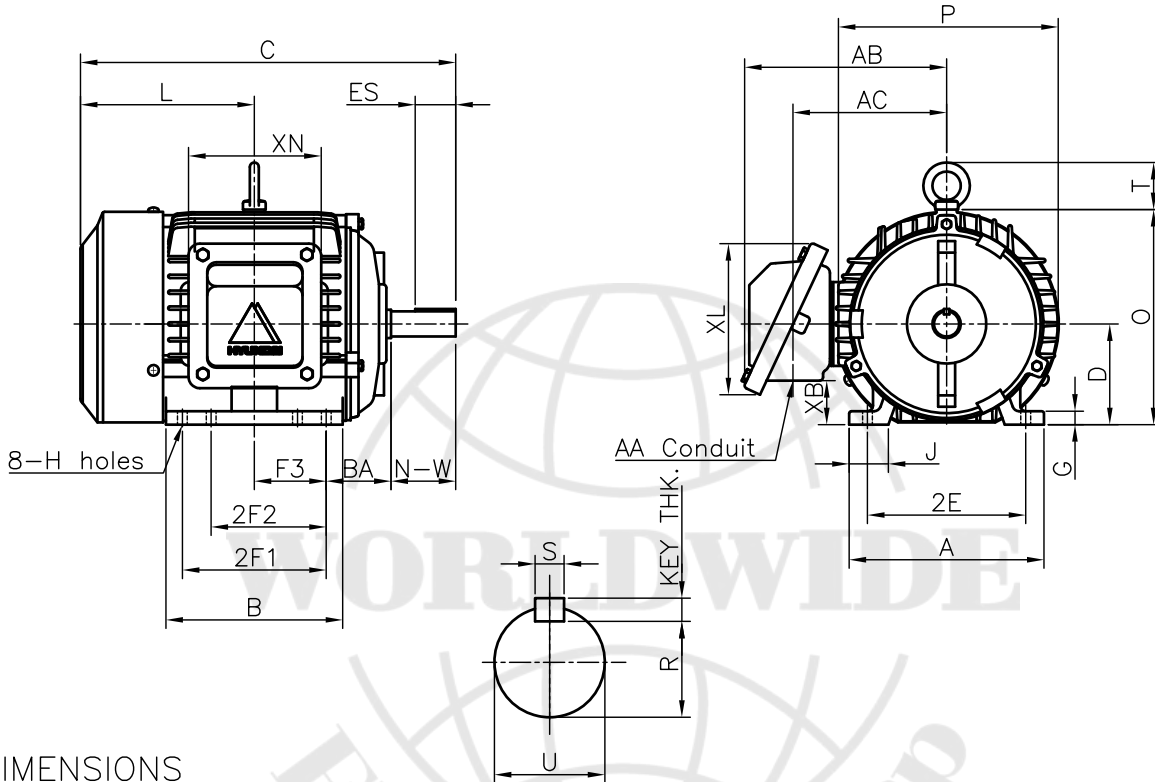

DIMENSIONS

M O U N T I N G									C O N D U I T   B O X						APPROX. WGT.(LB)
A	B	2E	2F1	2F2	F3	G	J	H	AA	AB	AC	XB	XL	XN	
6.78	6.15	5.50	5.00	4.00	2.50	0.47	1.36	0.34	0.75	7.02	5.34	1.53	5.26	4.61	55

O V E R A L L						S H A F T						KEY THK.	B E A R I N G	
BA	C	D	L	O	P	T	U	N-W	K E Y W A Y				DRIVE END	OPP. DRIVE END
									R	ES	S			
2.25	13.05	3.50	6.05	7.46	7.64	1.63	0.875	2.25	0.771	1.41	0.188	0.188	6205ZZ	6204ZZ

**NOTE**

- 1.Dimension "D" tolerance : +0.00inch - 0.03inch
- 2.Dimension "U" tolerance : +0.000inch - 0.0005inch
- 3.Dimension "R" tolerance : +0.000inch - 0.015inch

APPD BY	J.H.KIM	UNIT	INCH	SUBJECT	NEMA 145T	CAD PROJ \ FILE
CHKD BY	N.D.LEE	SCALE	1/8			SCALE-NEMA\A1102AA
CHKD BY	K.S.LEE	PROJEC'N	3rd Angle	TITLE <b>OUTLINE</b>		
DSND BY	S.W.SEO	DATE	2010.12.20			
				REF. NO	350A8102AA	Sheet No. of
				DWG NO	<b>350A8102AA</b>	Revision No. 0